

WARNING

- ADVANCE TECH HX IS NOT A ROPE GRAB AND IS NOT DESIGNED AS FALL PROTECTION, NOR TO CATCH A FALLING LOAD. HIGH PEAK FORCES GENERATED IN THESE SITUATIONS WILL DAMAGE THE ROPE OR CAM MECHANISM WHICH COULD RESULT IN INJURY OR DEATH.
- YOU COULD BE KILLED OR SERIOUSLY INJURED IF YOU DO NOT READ AND UNDERSTAND THE USER INFORMATION BEFORE USING THIS PIECE OF EQUIPMENT.
- SPECIAL TRAINING AND KNOWLEDGE ARE REQUIRED TO USE THIS EQUIPMENT.
- YOU MUST THOROUGHLY READ AND UNDERSTAND ALL MANUFACTURER'S INSTRUCTIONS BEFORE USE.
- USE AND INSPECT THIS EQUIPMENT ONLY IN ACCORDANCE WITH THESE INSTRUCTIONS.

THIS SHEET HAS BEEN PREPARED IN ACCORDANCE WITH THE REQUIREMENTS OF NFPA 2500.



MEETS THE PULLEY REQUIREMENTS OF NFPA 1983, INCORPORATED IN THE 2022 EDITION OF NFPA 2500.

ADDITIONAL INFORMATION

Additional information regarding Pulleys can be found in the following publications:

NFPA 1858 and NFPA 1983, incorporated into the 2022 edition of NFPA 2500

NFPA 1500

PRODUCT KEY

- | | |
|-------------------|---------------|
| 1. Carabiner Hole | 8. Side Plate |
| 2. Sheave | 9. Axle |
| 3. Center Plate | 10. Becket |
| 4. Rating | 11. MLN |
| 5. Warning | 12. Guide Pin |
| 6. Cam Lever | |
| 7. Cam | |

SMC's Advance Tech Pulleys are designed with the small mechanical advantage system in mind. An aggressive cam located inside the side plates close to the sheave means that cam action is immediate without loss of progress or energy which is apparent in prusik systems. Also exclusive to the Advance Tech HX is a spring loaded cam that doesn't require separate pins or other mechanisms to operate safely. Simply pull the cam lever back with your thumb to set the cam in a parked position and another flip of your thumb will engage the cam. Resets in piggyback rigs are fast and easy.

The Advance Tech Mate retains the stainless guide pins that help keep rigging clean, but is without the progress capture cam and becket making it a perfect ultra-compact companion for the Advance Tech HX.



BEFORE USE

The techniques employed in the proper and safe use of this equipment may only be learned through PERSONAL instruction received from an instructor who is well-qualified in all phases of vertical rope work. Such instruction will include an evaluation of your comprehension of, and ability to perform, the tasks required to safely and efficiently use this equipment.

Never attempt its use until you have received such instruction and are believed competent by your instructor.

These Pulleys are designed to be used with rope diameters ranging from 7 mm to 12.5 mm.

INSPECTION FOR USE

Visually and by touch, inspect these Pulleys for cracks, distortion, corrosion, scratches or gouges, sharp edges or rough areas that might abrade a rope. Compare these Pulleys with a new model if necessary to determine its condition.

- Ensure that cam spring is functioning and that the cam moves freely from the parked position to the fully engaged position.
- Check cam teeth for wear that would keep cam from engaging.
- Check Pulley wheels and ensure that they rotate freely.
- Check that side plates close completely.

Remove from service if there is any doubt about its safety or serviceability.

MAINTENANCE AFTER USE

Carefully clean and dry these Pulleys to remove all dirt, foreign material and moisture. Minor sharp edges may be smoothed with a fine abrasive cloth, before cleaning. Store in a clean, dry place. Repair the Pulleys only in accordance with the manufacturer's instructions.

Cam pivot may be lubricated with LPS#1 or equivalent to both lubricate and displace moisture.

Do not disassemble Pulleys.

The pressure to park the cam is set to specification at the time of assembly. Pressure can be increased or decreased by means of a small blade screw driver. Too light of pressure may result in inadvertent cam engagement while too heavy of pressure may restrict normal cam movement to and from the parked position.

REMOVAL FROM SERVICE

If the pulley has been dropped, impact loaded, disassembled, exposed to heat sufficient to alter its surface appearance, any part appears deformed, cracked, or gouged of more than a superficial nature, this pulley should be removed from service or returned to the manufacturer. The cost for the manufacturer to inspect and repair a pulley will likely exceed the cost of its replacement with a new model.

RECORDS

It is suggested that the user of these Pulleys keep a permanent record listing the date and results of each usage inspection. Such record should show, as a minimum, inspection for all of the following conditions:

- Cleanliness
- Proper functioning of the cam spring
- Proper engagement of the cam on the rope
- Dryness
- Freedom from scratches, gouges and sharp edges
- Freedom from corrosion
- Freedom from distortion
- User Information sheet present

USE OF THIS USER INFORMATION SHEET

It is suggested that this User Information sheet be retained in a permanent record after it is separated from the Pulleys, and that a copy of it be kept with the Pulleys.

It is suggested that the user refer to this User Information sheet before and after each use of the Pulleys.

LIFESPAN

The service life of Pulleys are largely dependent on the type of use and the environment used in. Under moderate use, with limited exposure to moisture, salt water, corrosive agents, excessive loads, shock loading and excessive wear, Pulleys may last many years. However, many events such as taking a large dynamic load, dropping, or other events which cause physical damage, can reduce the lifespan of these Pulleys dramatically.

You must inspect your Pulleys frequently and take personal responsibility for evaluating its condition and retiring unsafe gear. Inspection is extremely important, but visual inspection only will not assure that damage has not occurred. If history of the Pulleys is unknown or if based on the history of the use of these Pulleys there is any doubt regarding the safety of these Pulleys, it should be removed from service. You should destroy retired gear to prevent future use.

RIGGING

The Advance Tech HX Pulleys are designed for use on static and low stretch ropes from 7.0 mm to 12.5 mm. Ideal for use in situation's which call for rapid deployment of a mechanical Pulleys system requiring progress capture.

The integrated cam is retracted to the park position when you open the side plates and from there it is easy to rig a simple 4:1 system.

1. Start by attaching the rope end to the becket and then route rope down around a sheave on the Advance Tech Mate Pulley.
2. Then bring rope back up to the Advance Tech HX, place behind the guide pin on the non-cam side and then over sheave.
3. Repeat routing rope through the Advance Tech Mate and then finally bring rope up behind the guide pin on the cammed side of Pulleys before going over the sheave to form the rope tail.
4. Closing the side plates secures the ropes so that rigging is less prone to tangling, especially when your system is thrown in a gear bag.
5. Simply engage the cam and you are ready to haul.

An optional pull cord up to 3 mm diameter may be attached to the cam lever to provide easy access if the Pulleys is out of reach.



To avoid damaging the Pulleys side plates and cam, assure the side plates are closed prior to storing.

CAUTION: Cam operates in one direction only. Check Cam for proper engagement before use.



Quality Gear for Life

ADVANCE TECH HX **ADVANCE TECH MATE**



Made in the USA by
Seattle Manufacturing Corporation
 6930 Salashan Parkway
 Ferndale, Washington 98248
 800.426.6251 | www.smcgear.com

LIMITED WARRANTY

SMC products are warranted to the original retail purchaser in accordance with the full Statement of Limited Warranty printed on our web site, www.smcgear.com. Items that are claimed to be defective must be returned under a pre-assigned Return Authorization/CC Number and should include a detailed description of the conditions existing during use of the item, the place and date of the original purchase as well as a copy of the original invoice or receipt. Items being sent in for inspection may or may not be returned if the product in question is deemed potentially unsafe or non-functional.

If you do not completely understand any of the outlined user instruction provided on this sheet or if you have any questions please contact SMC at 800.426.6251 or info@smcgear.com.

154999C

Information for your permanent records:
 Date of Purchase: _____
 Purchased From: _____
 Part Number: _____

Becket Strength – The Advance Tech HX is loaded between the carabiner and becket holes by means of 1/2” diameter pins. Strengths can be utilized for system rigging guidance.

Breaking Strength
4,047lbf. (18.0 kN)

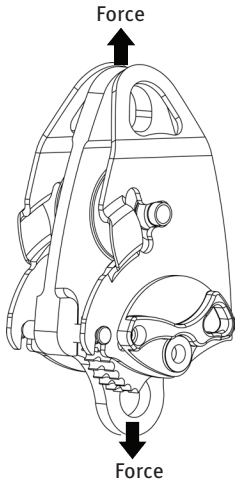

Cam Rating 1:1 Haul System Strength – This configuration is not recommended due to the relatively low strength results, but are included in these instructions to provide the necessary guidance when developing rigging methods. Single rope strand is rigged through the engaged cam and over one sheave. The force is applied between the end of the rope and the Pulleys carabiner hole.

Rope ⌀	Breaking Strength
7 mm	500lbf. (2.2kN)
9 mm	700 lbf. (3.1kN)
12.5mm	1,000 lbf. (4.4 kN)

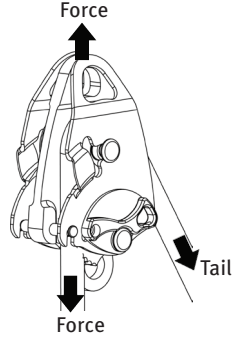

Double Pulleys Strength – The Advance Tech are each rigged with a loop of rope over both wheels and then pulled between the rope loop and carabiner hole. The cam was parked and not utilized for this test.

Rope ⌀	Breaking Strength
7 mm - 12.5 mm	Advance Tech HX 7,644lbf. (34.0 kN)
7 mm - 12.5 mm	Advance Tech Mate 7,644lbf. (34.0 kN)

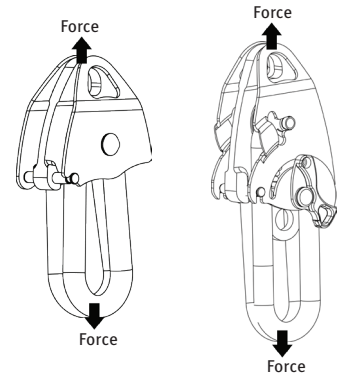

Cam Rating 4:1 Haul System Strength - Typical 4:1 system rigged using the Advance Tech HX with cam engaged on the 4th leg and a standard double Pulleys. The system utilized the becket on the Advance Tech HX Pulleys. System was pulled end to end using carabiner holes.

Rope ⌀	Breaking Strength
7 mm	2,000lbf. (8.9kN)
9 mm	2,500 lbf. (11.1kN)
12.5mm	4,500 lbf. (20.0 kN)

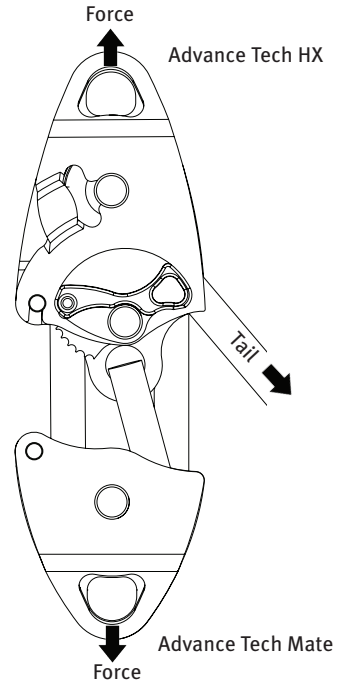

Cam Lock Adjustment – The pressure to park the cam can be adjusted by the user by means of a small flat-blade screw driver. To adjust the cam lock pressure, rotate the side plate opposite the cam counterclockwise open until you see the cam park adjustment screw. Turn the screw 1/4 turn and check for engagement. Too light of pressure may result in inadvertent cam engagement while too heavy of pressure may restrict normal cam movement to and from the parked position.



CONFIGURATION RATINGS

The Advance Tech Pulleys are designed primarily for rigging small lightweight mechanical advantage systems typical in rescue situations. Cammed Pulleys, like ascenders and other similar gear, require aggressively toothed cams to quickly and positively engage. However, these same aggressive teeth may be harmful to ropes if the cam is employed in high load situations. For situations when high loads are present the Advance Tech HX becomes a very effective prusik minding Pulleys by disengaging the cam and using prusiks. Simply attach prusiks in the normal manner and move cam to the parked position assuring that the teeth are out of the rope path. The stainless guide pins allow for better prusik-minding than all other prusik-minding pulleys.

CAUTION: Stainless guide pins should not be used as attachment points.

It can be difficult to judge when loads will exceed the designed capacity of the cam and the use of prusik is required. The following strength data has been provided for guidance in making rigging decisions.

CAM OPERATIONS

Parking Cam – To park the cam, rotate the cam lever clockwise until it clicks into park. Alternatively when optional cord is attached to cam lever, simply pull cord straight down until cam clicks into park.

Note: Pushing the cam lever against the Pulleys side plate may restrict movement of the cam to and from the parked position.



Engaging Cam – To engage the cam, rotate the cam lever counterclockwise. The cam is spring loaded so the cam is engaged at anytime it is not parked nor held in place by cord. If the Pulleys is out of reach you may use the tail of rope to flip cam lever releasing if from the parked position. When the optional cord it attached you can engage the cam by pulling the cord away from the Pulleys body.



CAUTION: NEVER release control of rope tail until you are certain that cam has engaged and is holding the load.

Releasing A Loaded Cam – While maintaining control of the load, slightly raise the load by pulling on the tail of rope while at the same time releasing the cam. The cam can then be rotated into the parked position, held open by hand or by pulling the cord while lowering the load. Use caution so that fingers or gear are not drawn into Pulley mechanism.

CAUTION: Always maintain control of the rope tail until you are certain that the cam has engaged and is holding the load. Failure to maintain control of the load may shock load the system which could result in serious injury or death.